

Ultra High Pressure Control
& Shut-off Valves for Severe
Service Applications

- Nuclear
- Marine
- Power Generation
- Industrial

A division of

lister since 1874



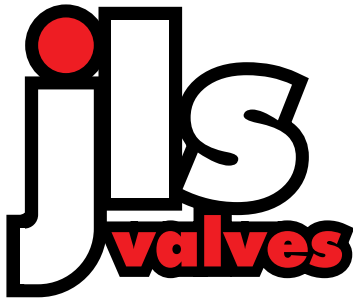

high performance products...

We specialise in the design, manufacture and supply of a wide range of ultra high pressure valves for use in a variety of demanding and severe service applications.

Our products are renowned for their long life and reliability. The high integrity, complete sealing of our shut off valves has been proven over decades of operating experience. The ease of operation of the balanced shut off type and the exceptionally fine flow adjustment possible using our control valves are distinct features of our range.

quality and reliability since 1874...

JLS valves is a division of James Lister and Sons Ltd, which was founded in Tipton by a local schoolteacher, James Lister, as a hardware and ironmonger shop.

Today the company continues to provide industrial supplies from its network of branches across the Midlands and South Wales, under the Lister brand, and also provides a range of other engineering related products and services.

From our headquarters in Smethwick, West Midlands, we also manufacture, supply and support valves worldwide.

A division of

lister since 1874

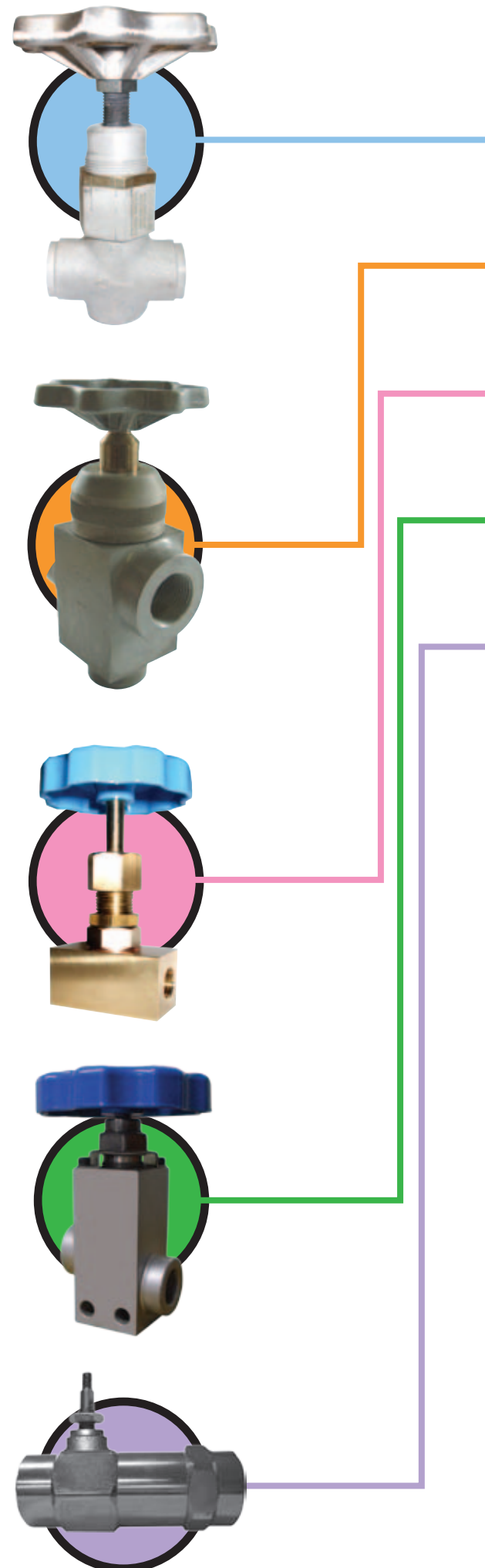

Stop and Control Valve

Balanced Shut-Off Valves Type 509

Instrument Control Valve

High Pressure Shut-Off Valve

Speed Control Valve

the JLS range of valves

Our needle valves are based on the world famous **Ermeto/Alenco valves** to which JLS valves acquired the design rights in 1990. We can provide replacement and specified valves for this range back to the 1950's, with over 12,000 drawings in our database.

In addition to the valves detailed in this catalogue we also offer a wide range of additional specialist valves and will engineer valves to meet specific applications and configurations.

The most popular valve types, many of which are normally available ex-stock, or with short lead-times, are shown to the left.

The below chart is an aid to selection based on required functionality (shut-off and / or controlled flow) and operating conditions (max hydraulic and / or pneumatic pressure, high temperature), but we are always delighted to hear from you to discuss your requirements in more detail.

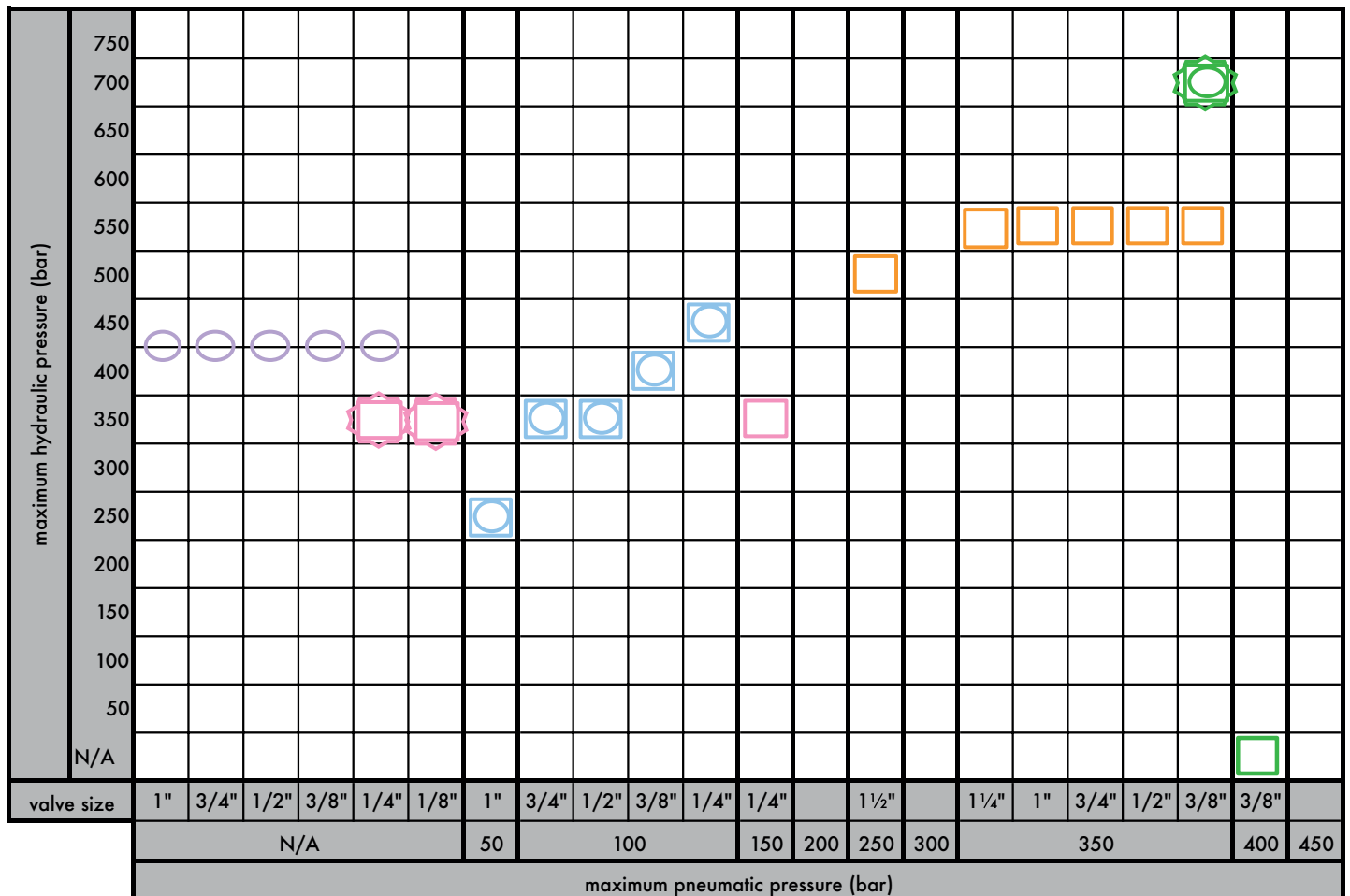

○ Controlled Flow □ Shut-off ☆ High Temperature

full details of the popular valve ranges are detailed overleaf

A selection of the **most popular valves** in the JLS range

Description	Purpose	Part No.		Ports*		Flow function		Max working pressure		Body matl : normal options		
				Nominal size	Shut off	Flow Control	Hydraulic - liquid	Pneumatic - gas	Mild steel	Stainless steel	Bronze (Al bronze)	
									suffix M	suffix HC	suffix AB	
Stop and Control Valve	General purpose high pressure isolation and flow control valves	In-Line Ports	Angle Ports									
		SCF 1/4 R	ASCF 1/4 R	1/4"	Y	Y	450	100	● E	○ P		
		SCF 3/8 R	ASCF 3/8 R	3/8"	Y	Y	400	100	● E	● E		
		SCF 1/2 R	ASCF 1/2 R	1/2"	Y	Y	350	100	● E	● E		
		SCF 3/4 R	ASCF 3/4 R	3/4"	Y	Y	350	100	● E	○ P		
SCF 1 R	ASCF 1 R	1"	Y	Y	250	50	● P	○ P				
Balanced Shut-off Valve Type 509	Higher pressure isolation valves with ease of operation	In-Line Ports	Offset Ports									
		W50904S		3/8"	Y		540	340	○ P	● E	● E	
		W50907S		1/2"	Y		540	340	● E	● P		
		W50929S		3/4"	Y		540	340	● E	○ P		
			W50911S	1"	Y		540	340	● E	○ P		
			W50902S	1 1/4"	Y		540	340	● P	○ P		
	W50914S	1 1/2"	Y		510	255	● P	○ P				
Instrument Control Valve	Small bore isolation valves for high temperatures/pressures	In-Line Ports	Angled Ports									
		W26394		1/8"	Y		340	N/A	● P			
		W26397		1/4"	Y		340	N/A	● P	● E	● E	
			W50808	1/4"	Y		340	140	● P	● E	● E	
High Pressure Shut-off Valve	Very high pressure valves for extreme conditions	In-Line Ports	Offset Ports									
		W50801		3/8"	Y		N/A	410		○ P	● E	
			W36922S	3/8"	Y	Y	680	340	● E	○ P		
Speed Control Valve	High pressure adjustable hydraulic flow valve											
		W70541S		1/4"		Y	420	N/A	● E	○ P		
		W70542S		3/8"		Y	420	N/A	● E	○ P		
		W70543S		1/2"		Y	420	N/A	● E	○ P		
		W70544S		3/4"		Y	420	N/A	● E	○ P		
		W70536S		1"		Y	420	N/A	● E	○ P		

* All inlet/outlet ports are BSP female as standard - other threadforms or port fittings/flanges available to special order ● standard/usual ○ option E normally Ex-stock P Produced to order

Stop & Control Valves

Extremely effective and reliable general purpose valve for high pressure hydraulic or pneumatic (inc dry non-corrosive gas) systems for positive shut-off or precise flow control.

The two-piece spindle and stem assembly construction allows a non-rotating stem for long life positive sealing and flow control.

The operating spindle is fitted with a locking nut to maintain fixed flow control if required.

Other features include an effective synthetic nitrile rubber O ring seal with fluon backing ring gland arrangement requiring no adjustment, a panel mounting nut and all sizes offered as in-line or angled port configuration allowing more freedom in pipe layout design.

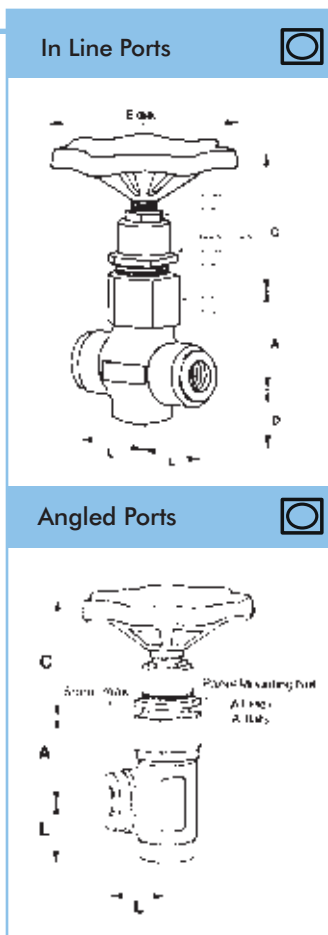

Balanced Shut-off Valves Type 509

High integrity shut-off valve for higher pressure hydraulic or pneumatic (only dry air and gas) systems (note that for use with pneumatic applications above 20bar valve must be degreased - please indicate on order).

Allows finger tip effort closure due to internal pressure balancing, rather than considerable effort on conventional valves, at these pressures.

Incorporates non-rotating stem for long life positive sealing and a non-rising handwheel.

Standard type 509 valves are supplied with stainless steel spindles, nitrile rubber gland seal and delrin seats.

For air or water applications the high duty bronze or stainless steel options should be chosen (not suitable for use with steam).

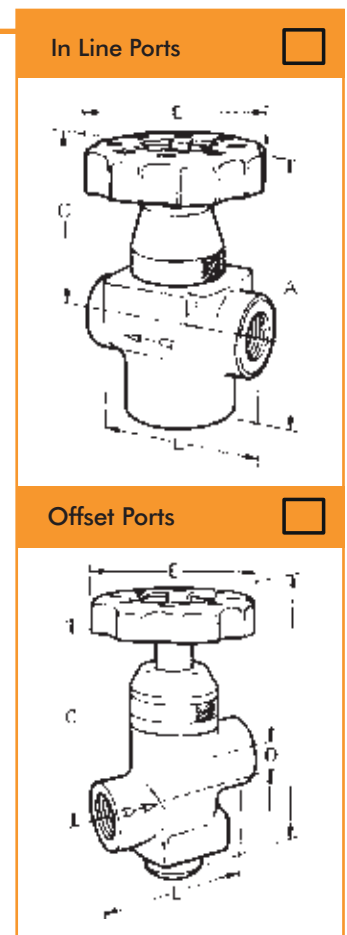

Temp range		Body dimensions								Spares kits part no.		Additional Options
Min	Max	A	B	C	D	E	L	Panel hole to clear M thread	A1 hex across flats			
°C	°C	mm	mm	mm	mm	mm	mm	mm	mm			
30°C	120°C	37		48	16	70	24	22x1.5	24	VKS80001U	4, 9, DEG	
30°C	120°C	41		56	20	80	30	26x1.5	30	VKS80002U		
30°C	120°C	50		66	24	100	35	32x1.5	36	VKS80003U		
30°C	120°C	60		75	30	120	43	36x2	46	VKS80004U		
30°C	120°C	67		87	37	140	51	42x2	50	VKS80005U		
30°C	100°C	98		63	-	63	63	-	-	VKS80021S	4, 9, DEG	
30°C	100°C	114		75	-	76	79	-	-	VKS80022S		
30°C	100°C	149		106	-	102	86	-	-	VKS80023S	3, 4, 9, DEG	
30°C	100°C	187		134	29	63	98	-	-	VKS80024S		
30°C	100°C	216		160	38	127	114	-	-	VKS80025S		
30°C	100°C	245		179	43	152	121	-	-	VKS80026S		
30°C	100°C											
30°C	250°C	98	10	85		64	44				1, DEG	
30°C	250°C	98	11	85		64	44			see separate table	1, 5, DEG	
30°C	100°C	113	11	89	25	51	44				1, DEG	
30°C	100°C	92		73	18		51		27		DEG	
30°C	250°C	111		90	11	76	51			V72398		
								Dia of orifice		Nitrile O ring	Viton O ring	
30°C	100°C			92			51	3.2		VK80030N	VK80030V	
30°C	100°C			98			51	4.7		VK80031N	VK80031V	
30°C	100°C			105			57	4.7		VK80031N	VK80031V	
30°C	100°C			127			57	4.7		VK80032N	VK80032V	
30°C	100°C			152			57	6.4		VK80033N	VK80033V	

non-functional dimensions subject to change

Speed Control Valves

For hydraulic applications only, permitting free flow of fluid in one direction (above a set pressure) and restricted flow along the same line in reverse direction.

Primarily designed for controlling the speed of rams etc. Standard valves are fitted with springs to lift at a set pressure of approximately 1.4 bar. Standard valves have mild steel bodies, sleeves, spindles and springs.

In Line Ports

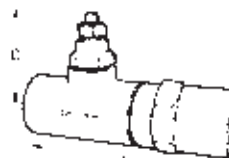

Spares Kits (Joint washer and 'O' Ring)					
Size (BSP)	O Ring	Part No.	Size (BSP)	O Ring	Part No.
1/4" BSP	Nitrile	VK80030N	3/4" BSP	Nitrile	VK80032N
1/4" BSP	Viton	VK80030V	3/4" BSP	Viton	VK80032V
3/8", 1/2"	Nitrile	VK80031N	1" BSP	Nitrile	VK80033N
3/8", 1/2"	Viton	VK80031V	1" BSP	Viton	VK80033V

Options key	
Suffix no.	Description
1	Plastic Handwheel 2"
3	Base Mounting Facility
4	Viton Seals/O Ring
5	Veemat Packing and Tinned Copper Washer
9	Prescothene Packing
DEG	Degreased for oxygen use

Instrument Control Valves

Capable of withstanding extreme conditions in small bore feed lines particularly in conjunction with instrument or control panels.

For isolating hydraulic pressure (including lubricating or fuel oils) up to 340 bar and 250°C or, with the soft seat W50808 angled port version, for gases up to pressure as high as 140 bar and 100°C.

1/4" valves are available in any of mild steel, stainless steel or aluminium bronze.

Standard valves are fitted with a stainless steel spindle and delrin seat.

Backnuts are supplied for panel mounting.

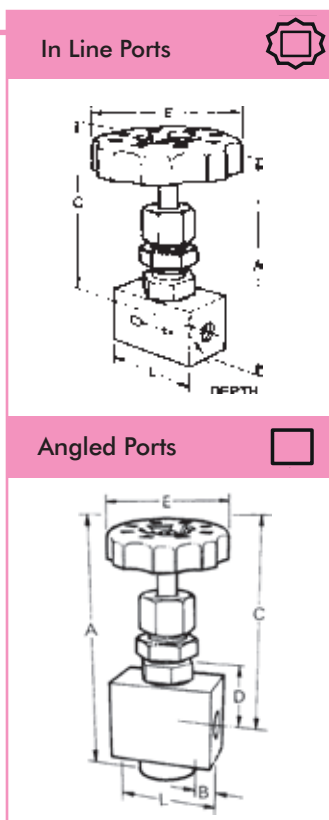

High Pressure Shut-off Valves

Available in 3/8" these very high pressure valves are suited to extreme operating conditions.

The W36922S has a mild steel body as standard but can be supplied in stainless steel and is suitable for hydraulic fluids up to 680 bar or non-corrosive gases up to 340 bar and temperatures up to 250°C. Although primarily a "shut-off" valve the solid cone spindle permits a reasonable degree of flow control with either oil or air.

The W50801 is designed for use with high pressure gas applications, up to 410 bar, to give leak-tight shut-off. The seat is in the form of a replaceable nylon pellet and spindle seal is effected by means of an O ring seal. An aluminium bronze body is standard but stainless steel is available as an option.

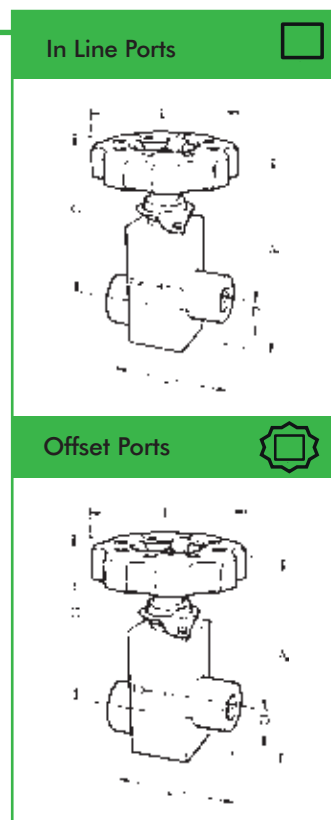

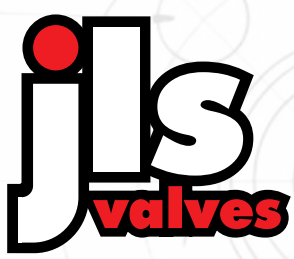
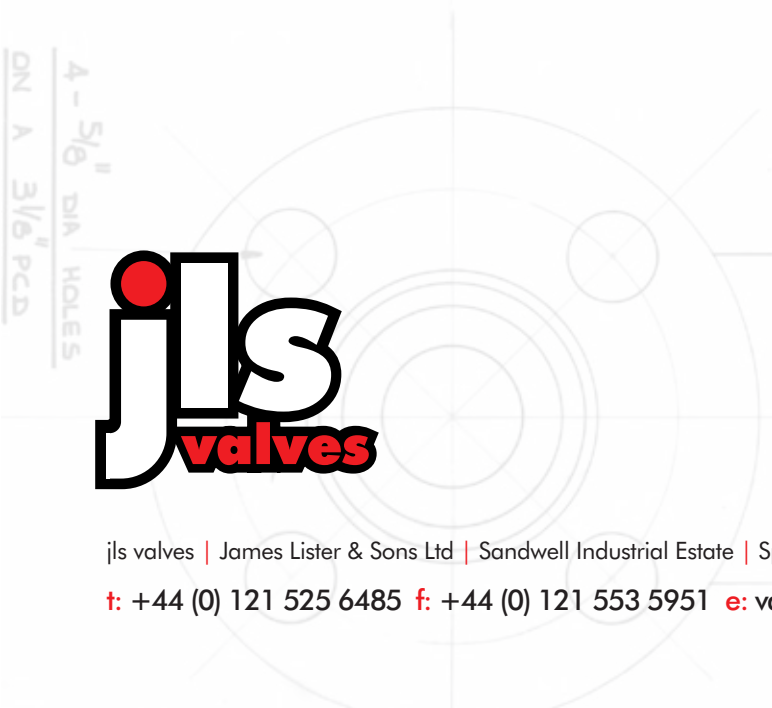
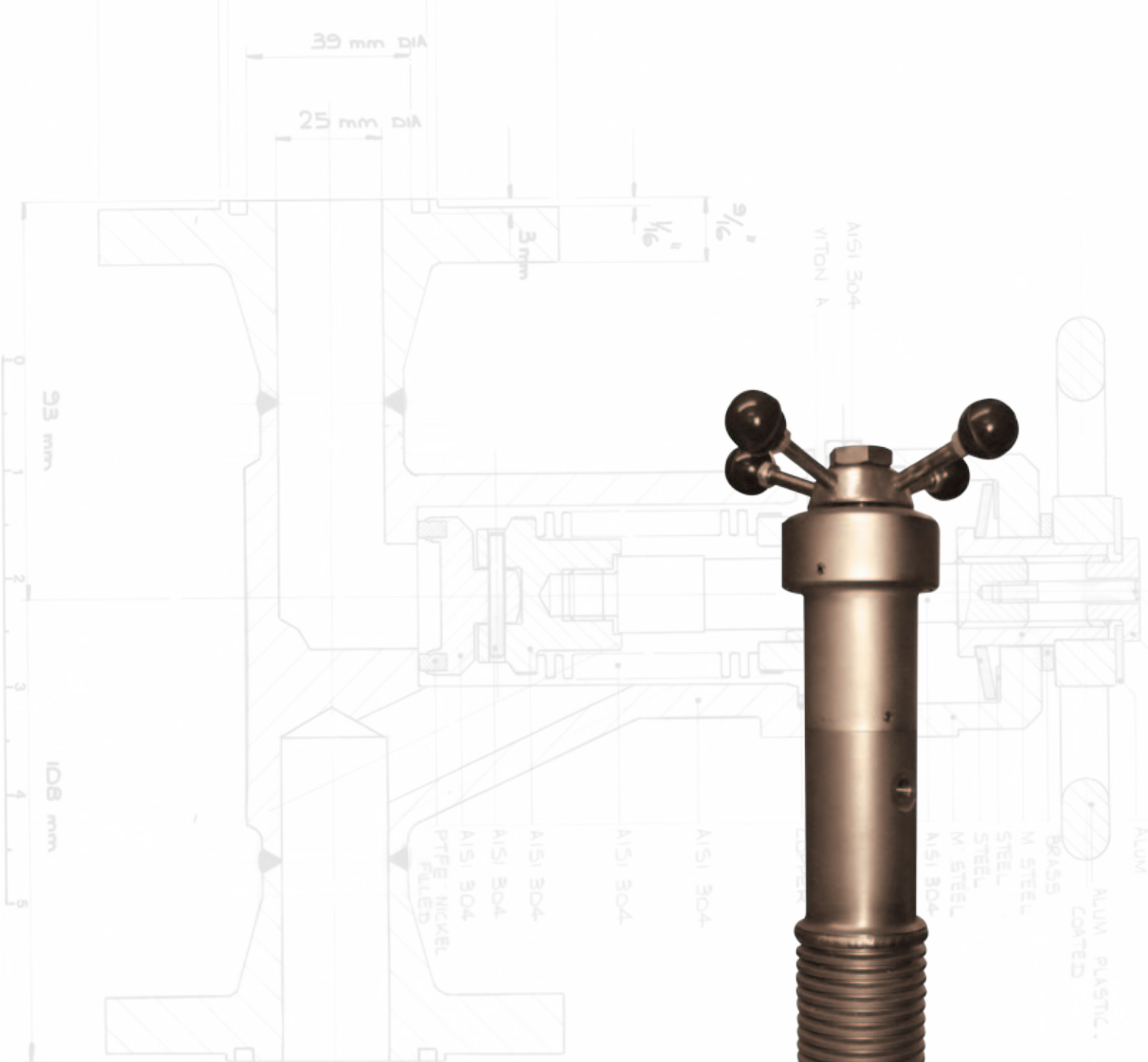

jls valves | James Lister & Sons Ltd | Sandwell Industrial Estate | Spon Lane South | Smethwick | B66 1QJ | UK
 t: +44 (0) 121 525 6485 f: +44 (0) 121 553 5951 e: valves@lister.co.uk w: www.jlsvalves.com